

 Model shown: A75R-10-12V
 A75R-20-12V

 Model shown: A75R-30-24V
 A75R-40-12V

Model shown: A75R-60-12V

SCR Railroad Applications

The La Marche A75R series battery chargers are specifically developed for the railroad market using proven SCR charging technology. Integrated features and functions are ideal for signaling, highway crossing, defect detectors and PTC's (positive train control). This filtered unit is designed and built to charge VRLA, Flooded Lead Acid and Nickel Cadmium batteries.

A75R's are packed with valued added features to make your DC system more reliable. Internal digital temperature compensation circuitry prolongs battery life with optional external temperature sensor that can be mounted near the battery system. State of the art lightning protection circuit protects the unit against lightning surges. Charger failure contacts are provided for remote annunciation. Remote shutdown capability allows the user to test DC System integrity or remotely shutdown the unit in emergency situations.

Mechanically designed to handle the most abusive environmental conditions. The A75R is built in a NEMA 1 enclosure and equipped with AREMA style hardware for the input and output connections. This convection cooled unit has components conservatively chosen to achieve MTBF in excess of 100,000 hours.

Standard Features

- Microprocessor Controlled SCR Charging Technology
- Single Phase AC Input 120/240V, 50/60Hz
- Automatic AC Input Voltage Compensation +/-10%
- Complete Isolation AC to DC
- DC Analog Ammeter and Digital Voltmeter
- Meets AREMA Specifications
- Meets ANSI C62-41 Standards for Surge Voltages
- 3-Year Warranty

Enhanced Features

- Superior Surge and Lightning Protection
- Automatic AC Input Voltage Selection (with No Tap Changes Required)
- Integrated Charger Failure Alarm with Form "C" Contacts
- Selectable Low DC Current Alarm to Detect when Charger is not in Service (Output Current is Below .1A)
- Remote Shutdown Capability for Placing Charger Offline for Battery Testing Purposes
- DC Output Filtering for Higher Quality Battery Charging and Compatibility with Sensitive Loads Even with Battery Disconnected
- Adjustable Current Limit From 50% to 105%
- Higher Temperature (Class H) Transformer Insulation and Conservative Component Selection for Long Life with Greater Safety Margins in Abusive Environments
- Selectable Temperature Compensation with Optional "Smart" Solid State External Probe



Model Number	DC Output				AC Input Current Draw @ 100% (load)	Enclosure	Overall Dimensions W x D x H	Net Weight*	
	Amps	Volts (Nominal)	Battery Cells					lbs	kgs
			Lead Acid	Ni-Cad					
A75R-10-12V-AB1	10	12	5-8	8-12	5.8 amps / 120 VAC 2.9 amps / 240 VAC	85	12" x 9.3" x 10" 305 x 237 x 254mm	42	19.0
A75R-20-12V-AB1	20	12	5-8	8-12	8 amps / 120 VAC 4 amps / 240 VAC	85	12" x 9.3" x 10" 305 x 237 x 254mm	44	19.9
A75R-40-12V-AB1	40	12	5-8	8-12	15 amps / 120 VAC 8 amps / 240 VAC	88-2	14.3" x 12.2" x 13.4" 356 x 310 x 340mm	67	30.4
A75R-60-12V-AB1	60	12	5-8	8-12	22 amps / 120 VAC 11 amps / 240 VAC	88-3	15.5" x 12.2" x 13.4" 394 x 310 x 340mm	89	40.3
A75R-30-24V-AB1	30	24	10-16	16-24	22 amps / 120 VAC 11 amps / 240 VAC	88-2	14.3" x 12.2" x 13.4" 356 x 310 x 340mm	87	39.5

*Weight does not include shipping packaging

Charger Specifications

<ul style="list-style-type: none"> • AC Input Single Phase 120/240V ±10% 50/60 Hz ±5% • Line Regulation ±10% • Load Regulation <±0.5% • Input Protection Fuse with surge protection • Output Current Limit Factory set at 100%, adjustable from 50-105% • Output Protection DC breaker or fuse with surge protection • Meters DC Output Digital Voltmeter (1%) DC Output Analog Ammeter (2%) • LED Indicators Current Limit Temperature Compensation Disable AC On Nickel Cadmium Lead Acid Charger Fail • Environmental Operating: -40° to 70°C (Output derated above 50°C by 3% with the internal temperature compensation enabled) Storage: -40° to 85°C (-40° to 185°F) Relative Humidity: 0 to 95% non condensing

<ul style="list-style-type: none"> • DC Output 12 Volts @ 10 Amps, 20 Amps, 40 Amps and 60 Amps Lead Acid: 5L, 6L, 7L and 8L Ni-Cad: 8NC, 9NC, 10NC, 11NC, 12NC 24 Volts @ 30 Amps Lead Acid: 10L, 12L, 14L and 16L Ni-Cad: 16NC, 18NC, 20NC, 22NC, 24NC • Adjustable Voltage Range (per cell) Lead-Acid Cells: 2.15 VDC to 2.35 VDC Ni-Cad: 1.39 VDC to 1.49 VDC • Mounting The enclosures can be wall or shelf mounted • Cable Entry Top • Finish Powder coat finish (RAL 7032) • Standards Meets AREMA specifications Meets ANSI C62-41 • Optional 11W External Temperature Probe 24 ft 11Y External Temperature Probe 100 ft
--

Model Number Nomenclature

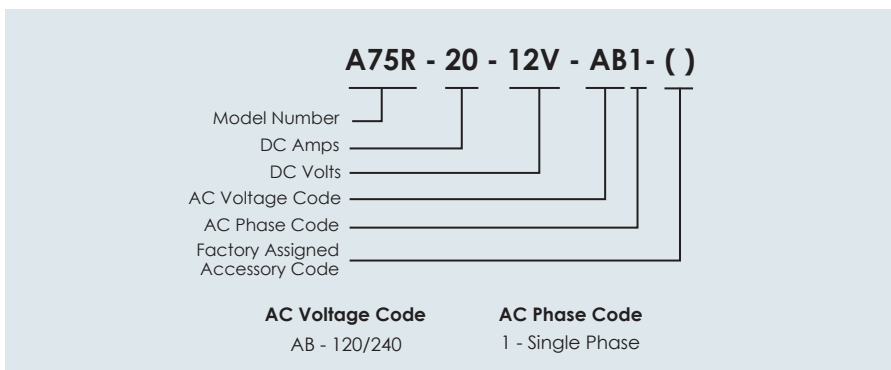

<p>Ordering Information</p> <p>When ordering, please specify:</p> <ul style="list-style-type: none"> - La Marche Model Number - Input Voltage - Number of Battery Cells - Amp Hour Capacity of Battery - Allowable Recharge Time from Full Discharge (where applicable)
